



OptiRAT[®] RACK

The OptiRAT[®] exhaust vented carousel rat caging system offers a unique means of large rodent housing in the animal care industry. This system is unmatched in space-efficiency and its ability to house rats in the best possible environmental conditions. The convection-assisted, low velocity, one-pass airflow through each cage provides animals with the gentle ventilation necessary to ensure maximum comfort in an ideal, low-stress living and breeding environment. With no motors or blowers, OptiRAT[®] equipped rooms are virtually noise, vibration, and odor-free.

OptiRAT[®] C86100X Rack Specifications

42-CageRat Rack Assembly, available in Polycarbonate (M suffix), amber polysulfone (P suffix), or smoke polysulfone (S suffix)

- Includes complete stainless steel rack assembly with reinforced polymer carousel, cage assemblies, casters, and 2 vent hose assemblies.
- Includes 42 rat cage assemblies with filters, feeders, cage cards, and water bottles
- Rack Dimensions -- 39.5”L x 39.0”W x 77.0” H.
- Rack Dimensions with 14 cages -- 39.5”L x 33.0”W x 77.0” H. (4 columns of cages removed for door clearance)
- Two vent hoses mount near top center of rack with quick-disconnect fittings.
- 550 lbs (250 kg) complete and ready for installation.
- Rack assembly is mounted on stainless steel casters with 4” diameter hi-temp ball bearing wheels. Two casters are provided with brakes and locks.
- Air flow requirements – 82 CFM recommended, 55 CFM minimum per rack.
- Full-height handles at each corner
- Pleated high-flow Reemay filter assemblies

Cage Specific Information
OptiRAT Cage
Outside dims – 14”(356 mm) L x 19.1”(485 mm) W x 8.6”(218 mm) H including feet
Inside dims – 12.8”(325 mm) L x 18.5”(470 mm) W (front) x 6.5”(165 mm) W (rear) x 8.1”(20.5 cm) H.
Floor area – 160 square inches (1032 sq. cm.)
Capacity – 2 rats 500 grams or heavier, 4 rats less than 400 grams
Cage Material – Makrolon [®] polycarbonate or Udel [®] polysulfone (amber or smoke color)
Feeder – polished stainless steel, 37 oz. (1.1 liter) capacity
Water Bottle – 2 each 405 ml (13.5 oz)
Enrichment – two raised shelves at front of cage

The following items are available as options:

- Trough tunnel that provides enrichment for the animal population.
- OptiRAT rack available with automatic watering option.
- Udel[®] M2000 amber polysulfone cage assemblies
- Udel[®] M2300 clear polysulfone cage assemblies

The OptiRAT[®] System offers closed-system, barrier isolation caging system providing unparalleled ease-of-use while maximizing population density and improving the welfare of both animals and caretakers.

Sheet 1

This specification applies to the following specific racks

Std: C86100M, C86100P, C86100S
Edstrom Watering: C86200M, C86200P, C86200S

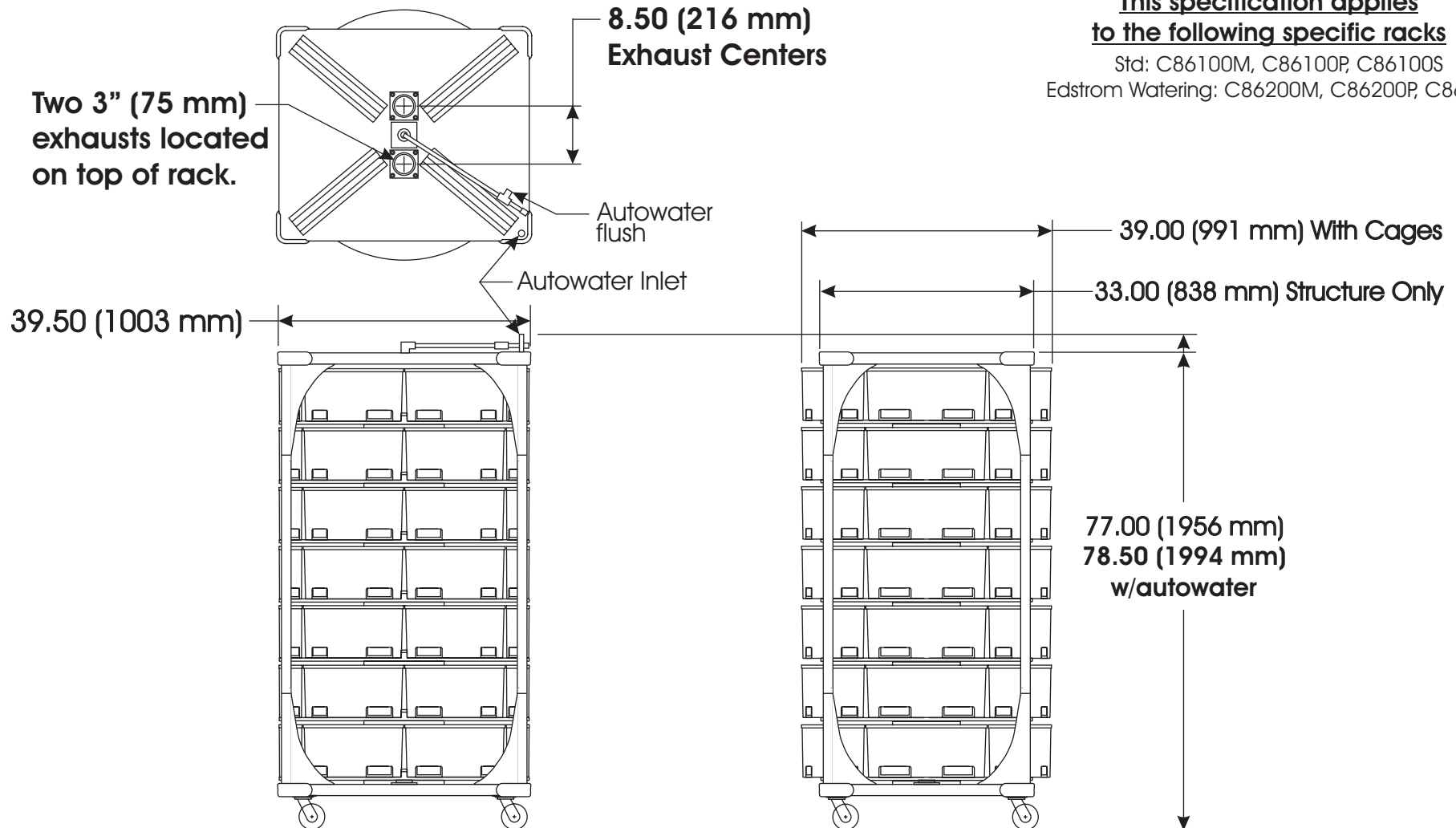

OptiRAT C86100X Rack Specifications & Dimensions

Dimensions in inches (millimeters)

 ANIMAL CARE SYSTEMS Inc.	Part Name: C86100X
	Engineering Specification Sheet
Drawn by: S.Corell	Date: 09/20/07
Revised: 20Nov2007	

Weight – Approx 550 Lbs (250 kg) with cages

Weight w/autowater -- 565Lbs (256 kg)

Autowater Connections – Type M stainless steel hose connection

Minimum Ventilation – 55 CFM (1550 l/m), 0.10" W.G. (25 pa)

Recommended Ventilation – 82 CFM (2312 l/m), .15"-.18" W.G. (38-45 pa)

Minimum Ceiling Exhaust – 4" (100 mm) Dia. Duct

Exhaust Hose – 2 ea. 3" (75 mm) Dia. Flexible x 120" (3050 mm) Lg.