



ErgoMICE70[®] RACK

The ErgoMICE70[®] exhaust vented carousel caging system offers a unique means of rodent housing in the animal care industry. This system is unmatched in space-efficiency and its ability to house rodents in the best possible environmental conditions. The convection-assisted, low velocity, one-pass airflow through each cage provides animals with the gentle ventilation necessary to ensure maximum comfort in an ideal, low-stress living and breeding environment. With no motors or blowers, ErgoMICE70[®] equipped rooms are virtually noise, vibration, and odor-free. And the ErgoMICE70[®] rack allows cage access from a comfortable working level.

ErgoMICE70[®] C89170M Rack Specifications

70-Cage Rack Assembly, Polycarbonate (also available in amber or clear polysulfone)

- Includes complete stainless steel rack assembly with reinforced polymer carousel, cages, casters, and 2 vent hose assemblies.
- Includes 70 mouse cage assemblies with filters, feeders, cage cards, and water bottles
- Rack Dimensions/70 cages -- 39.5”L x 39.0”W x 77.0” H. (1003 L x 991 W x 1956 H.)
- Rack Dimensions with 4 columns of cages removed for door clearance -- 39.5”L x 33.5”W x 77.0” H. (1003 L x 851 W x 1956 H.)
- Vent hoses mount at top center of rack with quick-disconnect fittings.
- 463 lbs (210 kg) complete and ready for installation.
- Rack assembly is mounted on stainless steel casters with 4” (100 mm) diameter hi-temp wheels. Two casters are provided with brakes and locks.
- Air flow requirements – 45 CFM (1269 l/m) recommended, 30 CFM (846 l/m) minimum per rack.
- Full-height handles at all four corners of rack
- Pleated high-flow Reemay filter assemblies with integral faceplates

Cage Specific Information
Outside dims – 13.5” (343 mm) Lg x 11.5” (292 mm) Wide (front) x 6.1” (155mm) H.
Inside dims - 12.5” (318 mm) Lg x 11.0” (279 mm) W (front) x 3.5” (89 mm) W (rear) x 5.06” (129 mm) H.
Floor area – 75 square inches (484 square centimetres)
Capacity – 5 - 25g mice
Cage Material – Makrolon [®] polycarbonate or Udel [®] polysulfone
Feeder – polished stainless steel wire, .51 liter (17 fl. oz) capacity
Water Bottle – 400 ml (13.5 oz)
Enrichment – raised shelves at front and rear of cage

The following are some of the options available with the ErgoMICE70[®] rack:

- Trough tunnel that provides enrichment for the animal population.
- Udel[®] M2000 amber polysulfone cage assemblies
- Udel[®] M2300 clear polysulfone cage assemblies
- Large capacity .89 liter (30 fl. oz) feeder

The ErgoMICE[®] System offers closed-system, barrier isolation caging system providing unparalleled ease-of-use while maximizing population density and improving the welfare of both animals and caretakers.

This specification also applies to the following racks

Std: C89170P, C89170S
 Watering option not available on the ErgoMICE70

Two 3 (75 mm) exhausts located on top of rack.

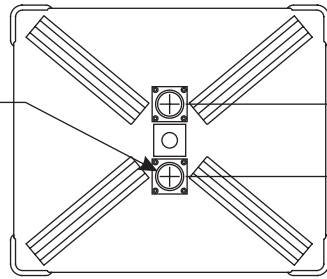

8.50 (216 mm) Exhaust Centers

39.50 (1003 mm)

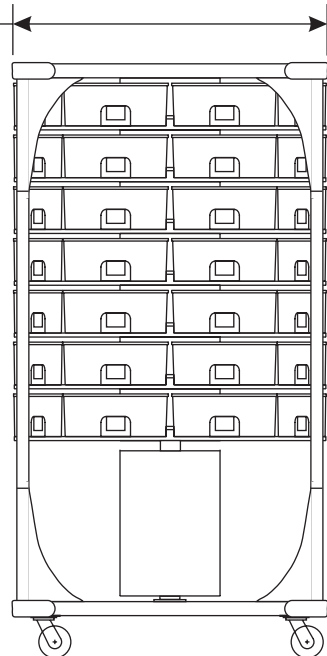

39.00 (991 mm) With Cages

33.50 (851 mm) Structure Only

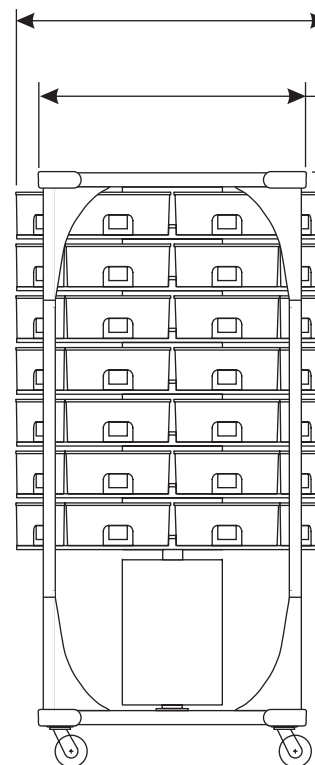

77.00 (1956 mm)

OptiMICE C89170M Rack Specifications & Dimensions

Dimensions in inches (millimeters)

 ANIMAL CARE SYSTEMS Inc.	Part Name: C89170M
	Engineering Specification Sheet
Drawn by: S.Corell	Date: 3/30/06
Revised: 040907 Revised part no., deleted autowater availability	

Weight 463 Lbs (210 kg) with cages
 Minimum Ventilation 30 CFM (840 l/m), 0.10 W.G. (25 pa)
 Recommended Ventilation 45 CFM (1260 l/m), .15 -.18 W.G. (38-45 pa)
 Minimum Ceiling Exhaust 4 (100 mm) Dia . Duct
 Exhaust Hose 2 ea . 3 (75 mm) Dia. Flexible x 120" (3050 mm) Lg.